

# **ASTRON CORPORATION**

## **SERVICE MANUAL**

**FOR: RM-50A, RM-50M, RS-50A, RS-50M**

Originally had a 2009 schematic that did not match the parts list.  
Transcribed and updated by Robert W. Meister WA1MIK August 2015.  
Edited/corrected July 2016.  
Added R7X November 2017.

**ASTRON CORPORATION  
9 ATRY  
IRVINE, CA 92618  
PH: (949) 458-7277, FAX: (949) 458-0826**

# **SECTION 1: GENERAL INFORMATION**

## **1.1 INTRODUCTION**

The ASTRON "50" series are heavy-duty power supplies capable of supplying 37 amps continuous at 13.8 VDC from 115 VAC line voltage. The output voltage is adjustable from approximately 11-15 VDC.

These supplies are protected against overload and short circuits by fold-back current limiting. The load is protected against over-voltage by a "crowbar" circuit, which initiates latched current limiting upon over-voltage, dropping the output voltage to a safe level.

The RS-50A and RM-50A are identical to the RS-50M and RM-50M except the "A" models do not have meters.

Two meters on the RM-50M and RS-50M front panel provide measurement of voltage and current being supplied to the load. The current meter is calibrated for 0-50 amps and the voltmeter reads 0-15 VDC. The power switch on the front panel controls AC power to the supply and indicates the presence of AC power when in the ON position. AC line surge protection is provided internally and a 10 amp AC line fuse is accessible at the rear panel.

## 1.2 SPECIFICATIONS

Input:	105-125 VAC, 60 Hz	
Output:		
Voltage (factory adjust):	13.8 VDC +/- 0.05 volts	
Current:	37 amps continuous, 50 amps ICS	
Ripple:	5 mv maximum (full load, low line)	
Regulation:	0.5% over load and line ranges	
Overload Protection:		
Current limit:	55 amps	
Fold-back current:	4 amps	
Over-voltage Protection:	16.5 VDC	
Operating Temperature Range:	-10 to +40 deg. C. for rated output	
Dimensions:	RM-50A, RM-50M	RS-50A, RS-50M
Height:	5.25 inches	6.00 inches
Depth:	12.5 inches	13.5 inches
Width:	19.0 inches	11.0 inches
Weight:	50 pounds	46 pounds
Chassis Type:	Rack Mount	Desk Top

## **1.3 PRECAUTIONS**

### **WARNING: HAZARDOUS VOLTAGES**

The RM-50M/RS-50M contains voltages that may be lethal. The case of the supply should not be removed without first disconnecting the AC supply. Servicing should be done only by qualified technicians.

### **CAUTION: HANDLE WITH CARE**

The weight of the RM-50M is 50 lbs so care is needed when removing it from the rack mount.

### **CAUTION: HEAT SINK TEMPERATURE**

Under some conditions the power supply heat sinks may reach high temperatures. Handle with extreme care after prolonged operation.

### **CAUTION: VENTILATION**

Do not operate this power supply in a concealed cabinet.

### **CAUTION: EXTERNAL BATTERY FUSING**

If a battery is used for standby operation and is connected directly across the power supply output, always connect a fuse and a blocking diode between the power supply and the battery. Failure to follow this practice could result in battery destruction and/or damage to the power supply should the crowbar circuit trigger, which will place a virtual short circuit across the battery. The battery should be disconnected when servicing the power supply to prevent accidental shorting of the battery voltage.

# **SECTION 2: CIRCUIT DESCRIPTIONS**

## **2.1 LINE CIRCUIT AND RECTIFIERS**

Refer to RM-50M/RS-50M Schematic on page 14.

The 115 VAC line voltage is supplied to transformer 8401 via the 10 amp back panel mounted fuse F1 and front mounted switch SW1. When the switch is on the indicator lamp indicates the presence or absence of 115 VAC. VR1 (MOV) provides protection against short duration high voltage line transients.

Diodes CR101 and CR102 in conjunction with capacitor C5 form a high current rectifier circuit for the power supply load. CR1, CR2 and C1 provide DC voltage for the voltage regulator, crowbar and series pass drive circuits. CR6 provides over-voltage protection for the regulator IC. CR7 protects the power transistors against over voltage when power is turned off and an external battery is connected across the load.

## **2.2 SERIES PASS POWER CIRCUIT**

The series pass power circuit is made up of two banks of four 2N3771 transistors operating in parallel as illustrated in the circuit showing Q101 and Q102. Resistors R101, R102, ... are provided in the emitter circuits for balancing the load among the eight transistors. CR7 provides protection against reverse voltage across the transistors. Q109 provides base current drive to the eight series pass transistors. It in turn, is driven by the voltage regulator circuitry contained on the PC board.

## 2.3 VOLTAGE REGULATOR

The uA723/LM723 IC (A1) in conjunction with associated circuitry, performs the function of voltage regulator, fold-back current limiting and provides drive current for the series pass circuit. See IC manufacturer's data book for details on the internal operation of the uA723/LM723.

Refer to Simplified schematic on page 13.

Voltage regulation is accomplished within the IC by comparing the scaled down supply output voltage (from the wiper of R5) to an internal 7.2 volt reference voltage. The reference voltage (pin 6) is connected to the non-inverting input (pin 5) of an internal op amp. The scaled down power supply voltage from R5 is connected to the op amp inverting input (pin 4) providing negative feedback.

If the power supply output voltage attempts to change, the IC output at pin 10 changes in the opposite direction, thus maintaining the output voltage constant for a given setting of R5.

The IC internal op amp maintains null between its two inputs, i.e. the inverting input through negative feedback, is maintained equal to the 7.2 volt reference. Therefore the output supply voltage will go up or down to accommodate a change in the setting of R5. This allows the output voltage to be adjusted to any value between 11 and 15 volts with the voltage division ratio provided by the combination of R5, R6 and R7. The factory selects R6X (across R6) to set the maximum output voltage to 15 volts. On newer supplies, R7X (across R7) sets the maximum output voltage.

The current from the 723 IC is amplified by Q2 and applied to the base of the 2N3771 series pass drive transistor. As noted in the voltage chart on the schematic, the regulator IC output voltage increases as power supply loading increases to compensate for the increased voltage drop across R1, R1X and the series pass circuit.

At full load, the voltage at the current limit input of the IC (pin 2) is around 14 volts as determined by the ratio of R4 and R3, R3X which sets the point at which current limiting begins. As the load is increase above full load, the differential between pins 2 and 3 (current sense input) increases until the internal current sense transistor begins to conduct (at 52 amps, factory set by R3X). Fold-back current limiting then occurs and the load current and output voltage decrease with decreasing load resistance until the short circuit current of 4 amps is reached. The short circuit current is factory set by selecting the value of resistor R1X. Diodes CR3 and CR6 prevent damage to the circuits by capacitive discharge or an external battery when power is turned off. CR4 stabilizes current in the limiting mode, preventing overheating due to current drift.

## **2.4 CROWBAR CIRCUIT**

The power supply load is protected from over-voltage by the crowbar circuit, which triggers at 16.5 volts. Zener diode CR4 maintains a voltage 5.6 volts lower than the power supply voltage at the emitter of Q1 while the voltage at the base of the transistor is determined by the voltage divider R8 and R10. As the output voltage increases, the voltage at the emitter of Q1 increases by the same amount while the base voltage increases according to the ratio of R8 and R10. At 16.5 volts, the base becomes more negative than the emitter to the extent that Q1 conducts, producing a voltage across R11 sufficient to trigger SCR1. When triggered, SCR1 acts as a virtual short circuit causing current limiting and subsequent low voltage output. Once triggered on, the SCR will continue to conduct until power is turned off.

Capacitors C6 and C102 in the gate circuit of SCR1 prevent false triggering from voltage transients.

## **2.5 METER CIRCUITS**

The current meter uses R102 as a meter shunt for measuring relative current. Although only one eighth of the current is measured, the meter is calibrated at full load by adjustment of R103 and therefore accurately indicates the full load current. The voltmeter is calibrated by R104 after setting the supply output voltage to 13.8 VDC with a calibrated external meter.

# **SECTION 3: INSTALLATION**

## **3.1 GENERAL**

The RM-50A/RM-50M is supplied in a rack mount configuration and may be mounted in any standard 19" rack mount cabinet with suitable ventilation. The power supply generates appreciable heat when operated at full load and requires an adequate airflow for cooling. It should always be mounted with adequate clearance above and below to provide convective cooling. Forced-air cooling may be required if other equipment generating relatively high levels of heat is enclosed in the same cabinet. DC output wiring should be of sufficient gauge to carry the current without excessive voltage drop.

## **CAUTION**

If a battery is used for standby operation and is connected directly across the power supply output, always connect a fuse and a blocking diode between the power supply and the battery. Failure to follow this practice could result in battery destruction and/or damage to the power supply should the crowbar circuit trigger, which will place a virtual short circuit across the battery. The battery should be disconnected when servicing the power supply to prevent accidental shorting of the battery voltage.



# **SECTION 4: SERVICING**

## **4.1.1 PRECAUTIONS**

See Section 1.3.

## **4.1.2 TECHNICAL BULLETINS**

From time to time, Technical Bulletins may be issued to enable updating of equipment, provide information or to meet specific operational requirements.

## **4.2 MECHANICAL**

Access to the inside of the power supply for servicing may be obtained by removing the six screws holding the top lid in place.

## **4.3 TEST AND ADJUSTMENT**

All power supply parameters previously defined are factory adjusted and normally will not require field adjustment. However, if certain components are replaced or a malfunction is suspected, it may be necessary to perform test and adjustment as defined in the following sections.

### **4.3.1 TEST EQUIPMENT REQUIRED**

Voltmeter	DC, 0-25 volts, sensitivity min. 20K ohms/volt
Ammeter	DC, 0-100 amps
Variable load	0-100 ohms, rated at 70 amps minimum

### **4.3.2 OUTPUT VOLTAGE**

R5 controls the output voltage and may be adjusted to set it to exactly 13.8 volts. If calibration of the front panel meter is suspect, use a known accurate voltmeter for this adjustment, then calibrate the front panel meter by adjusting R104.

### **4.3.3 OUTPUT CURRENT**

Output current at rated load may be checked by connecting the ammeter in series with the load and adjusting the load for 37 amps. If the panel mounted current meter does not read 37 amps, it may be recalibrated by adjusting R103.

### **4.3.4 FOLD-BACK CURRENT**

To check the fold-back current limiting point, connect the load to the output and adjust for 52 amps. Decreasing the resistance of the load should cause current to begin decreasing to 4 amps when the load reaches zero resistance. Resistor R3 in parallel with R3X (factory selected) determines the current limit point, i.e. the point where fold-back begins. Resistor R1 in parallel with R1X (factory selected) determines the short circuit limit of 4 amps.

In the event of component replacement, it may be necessary to change the values of R3X and R1X to reset these currents to design limits. Increasing the value of either network decreases their respective current values.

### **4.3.5 CROWBAR VOLTAGE**

To test for proper operation of the crowbar circuit, momentarily short across resistor R7. This causes the output voltage to rise to approximately 17 volts and should trigger the crowbar circuit.

## 4.4 TROUBLESHOOTING

Refer to RM-50M/RS-50M Schematic on page 14.

Remove the top cover to gain access to the inside of the power supply and check for proper operation of the transformer primary and secondary circuits including the power rectifier circuit CR101, CR102 and capacitor C5 (large chassis-mounted electrolytic capacitors). A check of voltage present at the I/O pins of IC A1 (uA723/LM723 voltage regulator) as compared to the A1 voltage chart shown on the schematic should provide an indication of the nature of the problem. If the voltage regulator is suspect, it can be replaced by removing the two PC board mounting screws and replacing the IC in the socket provided.

Since the heat sink mounted series pass power transistors operate at high junction temperatures, a failure in this area is most probable. Junctions may be checked for shorts or opens by disconnecting one end of the 0.05 ohm balancing resistors (R101, R102, ...) in their emitter circuits.

Note that due to the use of R102 as a meter shunt to measure relative current rather than absolute current, a failure of Q102 will cause false current readings. An open series pass transistor may not be apparent in terms of the current reading but may be detected by a significant drop in its case temperature. A shorted transistor will cause either current limiting or crowbar triggering.

## SECTION 5: PARTS LIST

Editor's Note: Some of the parts have been replaced as the power supplies went through design revisions. The parts list below closely matches the 1996 schematic at the end of this file but I think the manual was written prior to 1990. The schematic that originally came with the file was dated 2009.

<b>Designation</b>	<b>Description</b>
A1	LM723CN voltage regulator, TI, Motorola
C1	2,200 uF 35V radial electrolytic capacitor
C101	2,200 uF 16V electrolytic capacitor
C102	0.33 uF 50V ceramic capacitor
C2	0.1 uF 50V capacitor
C3	0.001uF 100V capacitor
C4	100 uF 25V electrolytic capacitor
C5 (2)	50,000 uF 25V computer grade electrolytic cap.
CR1, CR2	1N5404 rectifier diode
CR101, CR102	1N1184A rectifier diode, 40 amp, 100 volt
CR3	1N4148 small signal diode
CR4	1N5232B zener diode
CR5, CR8	1N4002 diode, 1 amp, 100 volt
CR6	P6KE39A 39 volt 600 watt transient suppressor
CR7	MR751 rectifier diode, 6 amp, 100 volt
F1	10 amp 250 volt MDL fuse (should be 12 amp)
IM	Panel meter, 0-50, Astron model 1-50 (1mADC)
Q1	2N3906 PNP transistor
Q101-Q109	2N3771 NPN transistor, 30 amp, 40 volt
Q2	TIP29 NPN transistor, TI, Motorola
R101-R108	0.05 ohm 5W wire-wound
R113	4.7 ohm 2W
R114	500 ohm 0.5W pot, 1T
R115	20k 0.5W pot, 1T
R5	1k 0.5W pot, 1T
RXXX	All other resistors, 0.5W 5% CF
SCR1	SO565J 50 amp, 50 volt SCR
SW1	LRA211RSB/125N illuminated AC rocker switch
T1	Transformer, Astron 8401
VM	Panel meter, 0-15, Astron model 1-15 (1mADC)
VR1	V130LA10A MOV, 10 amp, 130 volt, GE

Note: Other manufacturer's equivalent capacitors and resistors with the same specifications may be substituted for those specified above. Industry standard semiconductors from several manufacturers may be used for replacement.

# **SECTION 6: PARALLEL**

## **6.1 PARALLEL OPERATION**

Two units may be set up in parallel to double the current capacity by using the following procedure.

Connect the negative output terminals of two power supplies using 10 gauge or large wire (depending on the distance between the units).

Connect the positive output terminals using the same gauge and same length wire.

The output voltage of each unit must be set to the same voltage.

Connect a wire from the red terminal, marked "FOR PARALLEL OPERATION ONLY" on power supply "A" to the same red terminal on power supply "B".

Connect the negative load to the negative output terminal of power supply "A" and connect the positive load to the positive output terminal of power supply "B".

This will allow the power supplies to track and share the load equally.

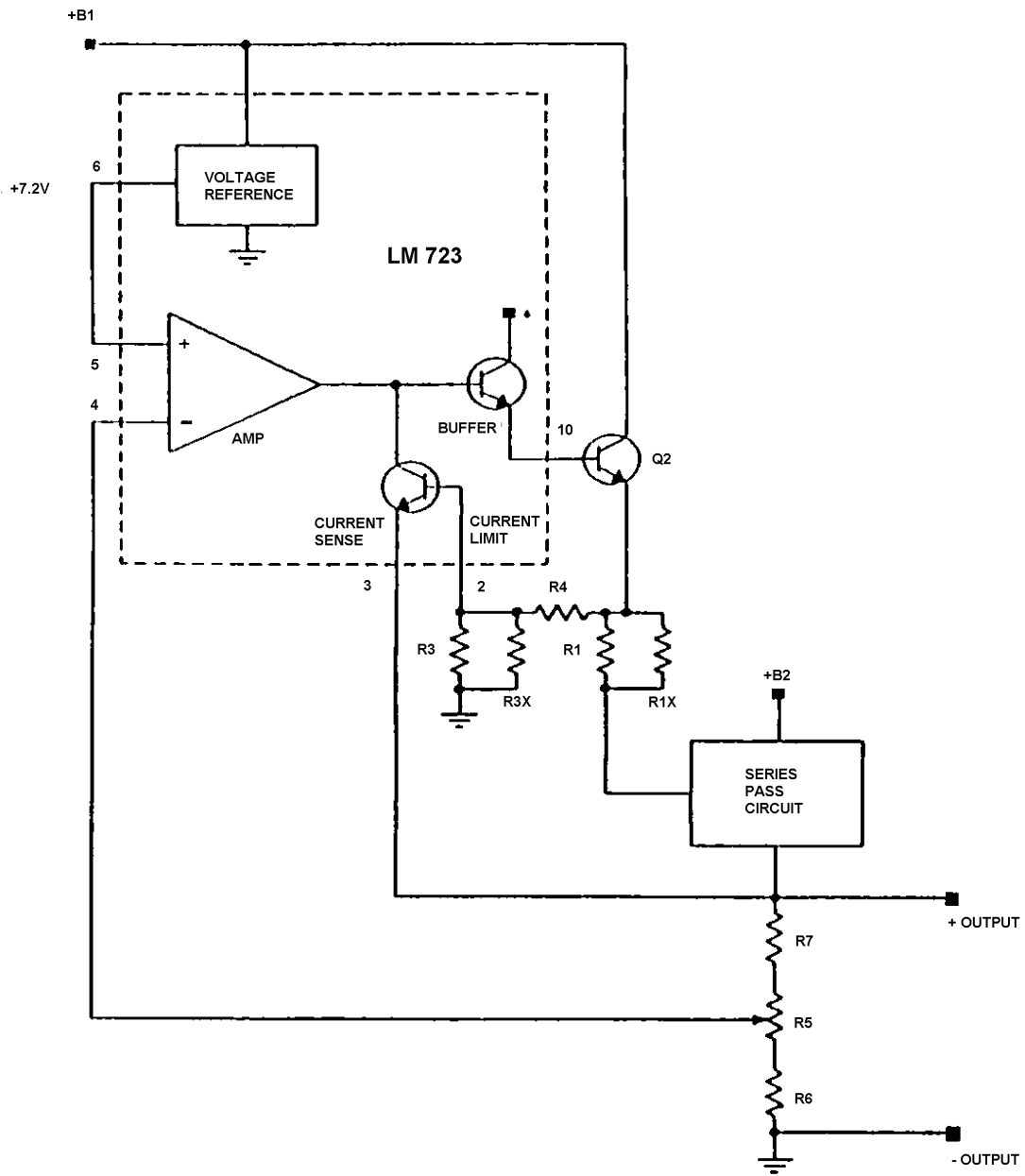

SIMPLIFIED SCHEMATIC

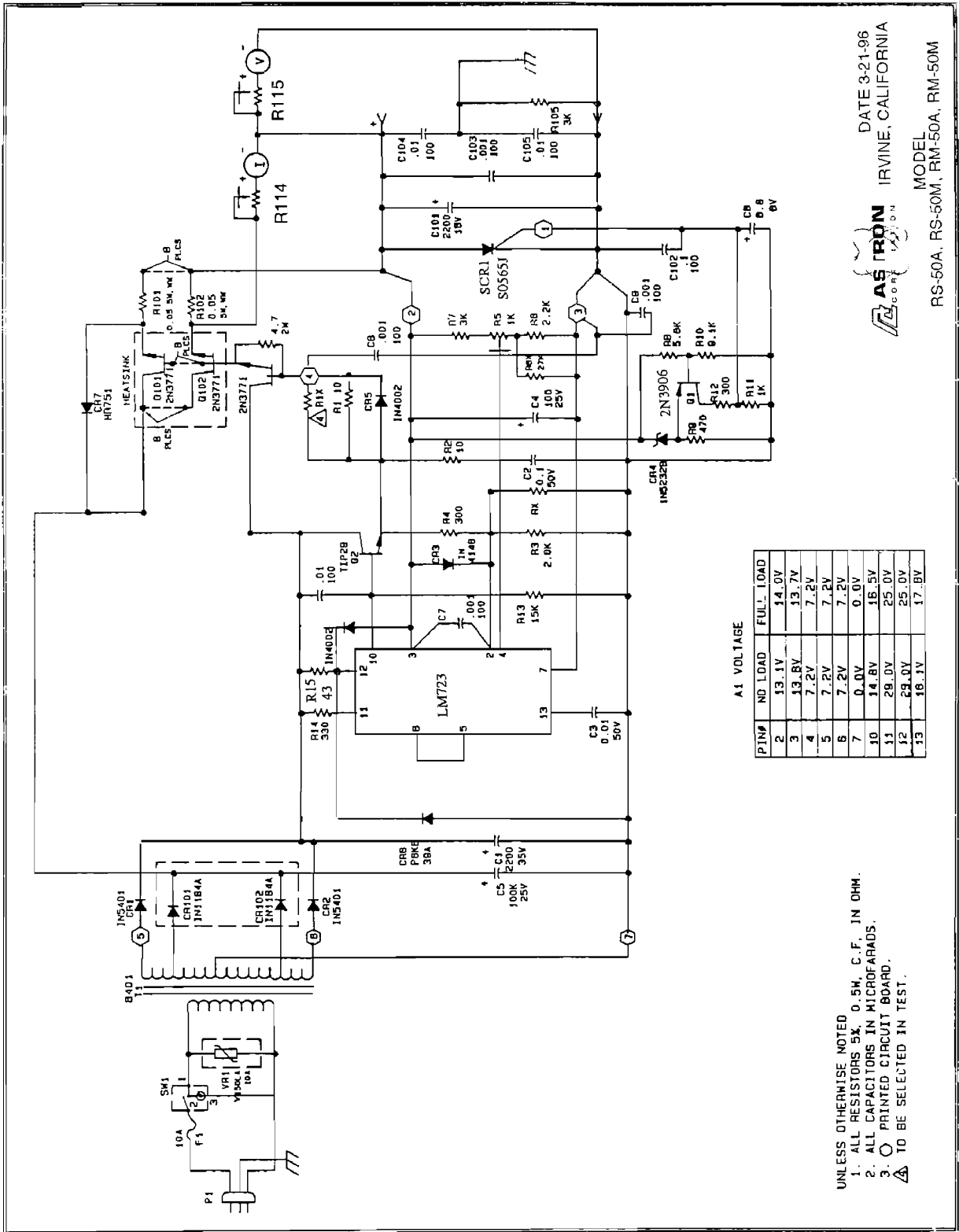

DATE 3-21-96  
 IRVINE, CALIFORNIA  
 MODEL RS-50A, RS-50M, RM-50A, RM-50M



A1 VOLTAGE

PIN#	NO. LOAD	FULL LOAD
2	13.1V	14.0V
3	13.8V	13.7V
4	7.2V	7.2V
5	7.2V	7.2V
6	7.2V	7.2V
7	0.0V	0.0V
10	14.8V	15.5V
11	29.0V	25.0V
12	29.0V	25.0V
13	18.1V	17.8V

UNLESS OTHERWISE NOTED  
 1. ALL RESISTORS 5%, 0.5W, C.F. IN OHM.  
 2. ALL CAPACITORS IN MICROFARADS.  
 3. ○ PRINTED CIRCUIT BOARD.  
 △ TO BE SELECTED IN TEST.